

Notice: This drawing contains proprietary information and shall not be used or reproduced or its contents disclosed in whole or in part, without the prior written consent of the Mann Teknik AB

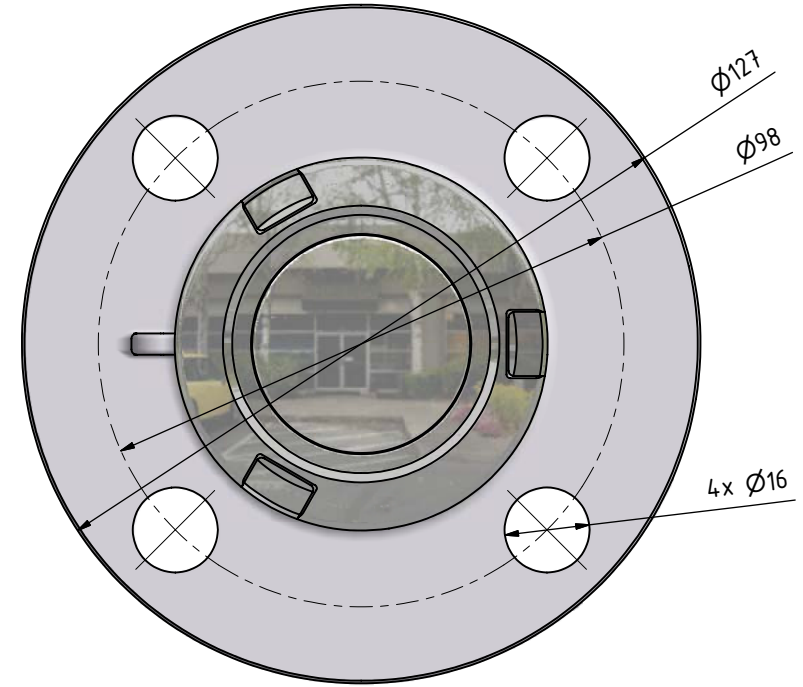
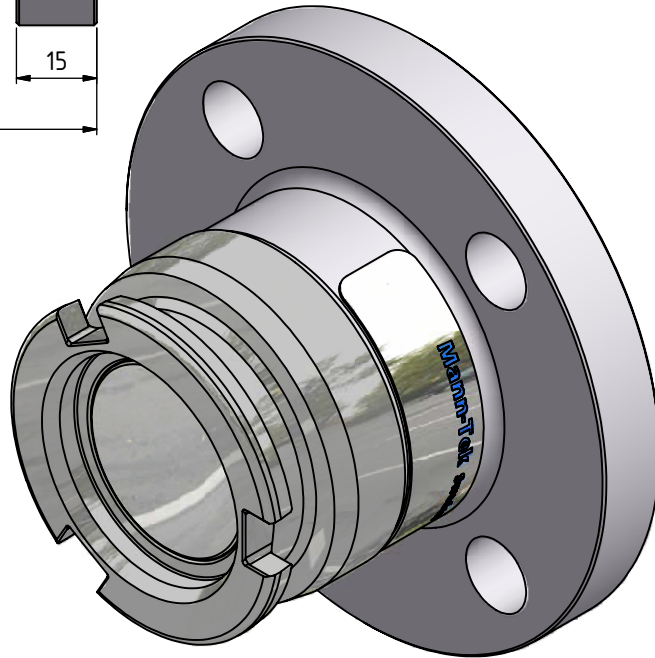
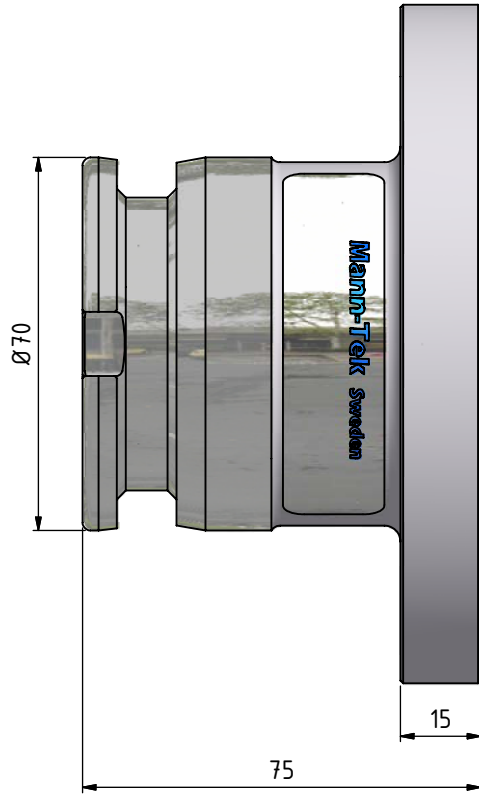

Dimensions are in metric.

Detail No:	Material	Ytbeh./Treatment	
<b>Mann</b> T e k	Designed/drawn by A.Eskilsson	Scale: 1:1	Dimension with no tolerances acc to Machined SS-ISO 2768-1 medium Weld Forge SS-ISO 2768-1 coarse Surface roughness ISO 1302 Form & position tol SS ISO 1101
	Checked M.Bäckström	Date 2004-09-01	
	Approved T.Mann		
Tank unit 2" Flange 1½" ANSI 150 PSI			Data nr./Comp No. T255B1101
			Blad/Sheet 1 / 1
			Drawing No. T255B1101-1
			Rev.

NO.	Revision comprises	Date	Sign.	Appr by
-----	--------------------	------	-------	---------